

maxilift 5500 cobra

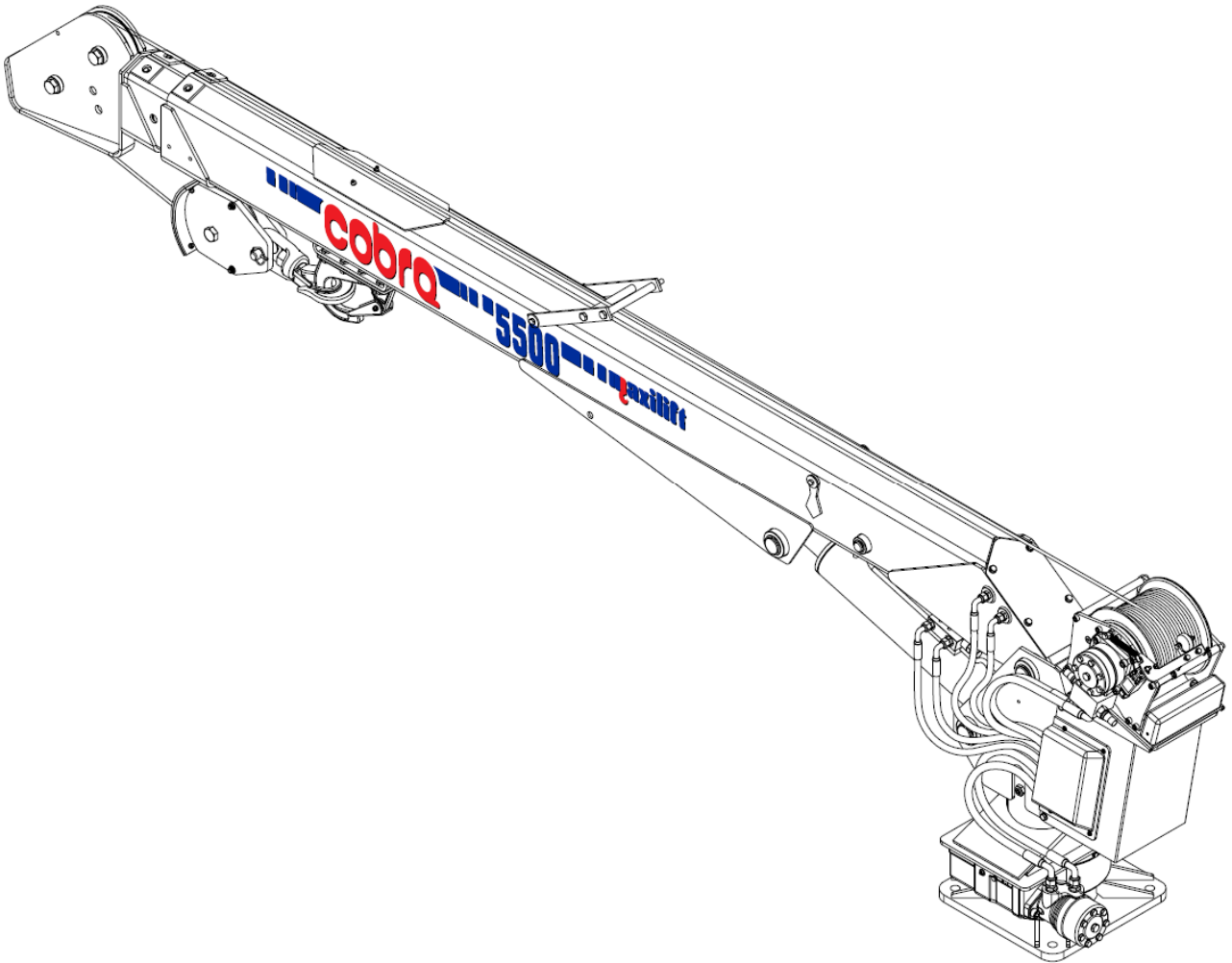

TECHNICAL SHEET

MP.0.205
Rev. 0



Next Hydraulics[®]
RAISE YOUR EXPECTATIONS

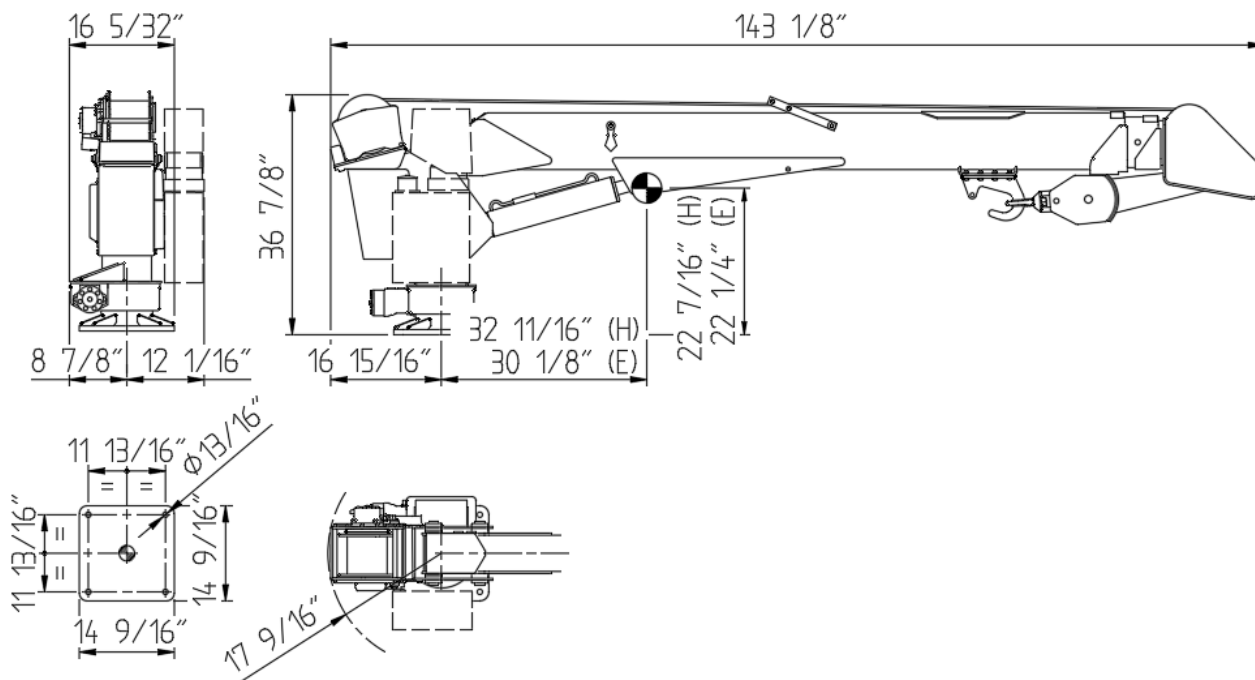
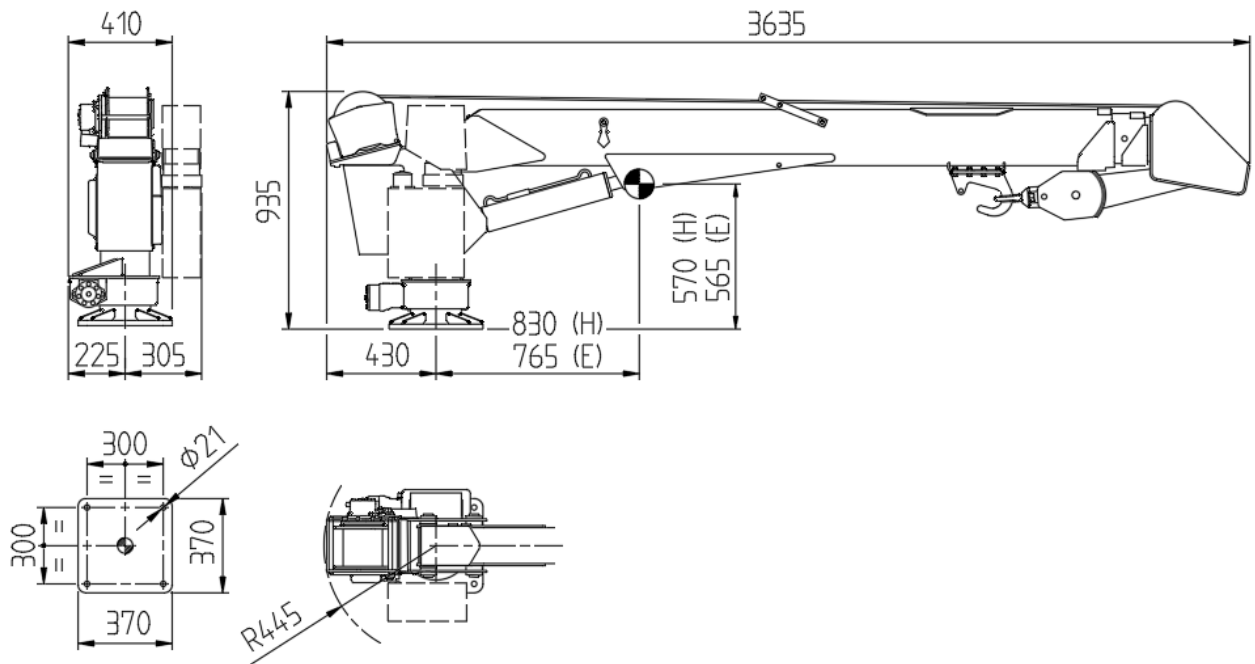

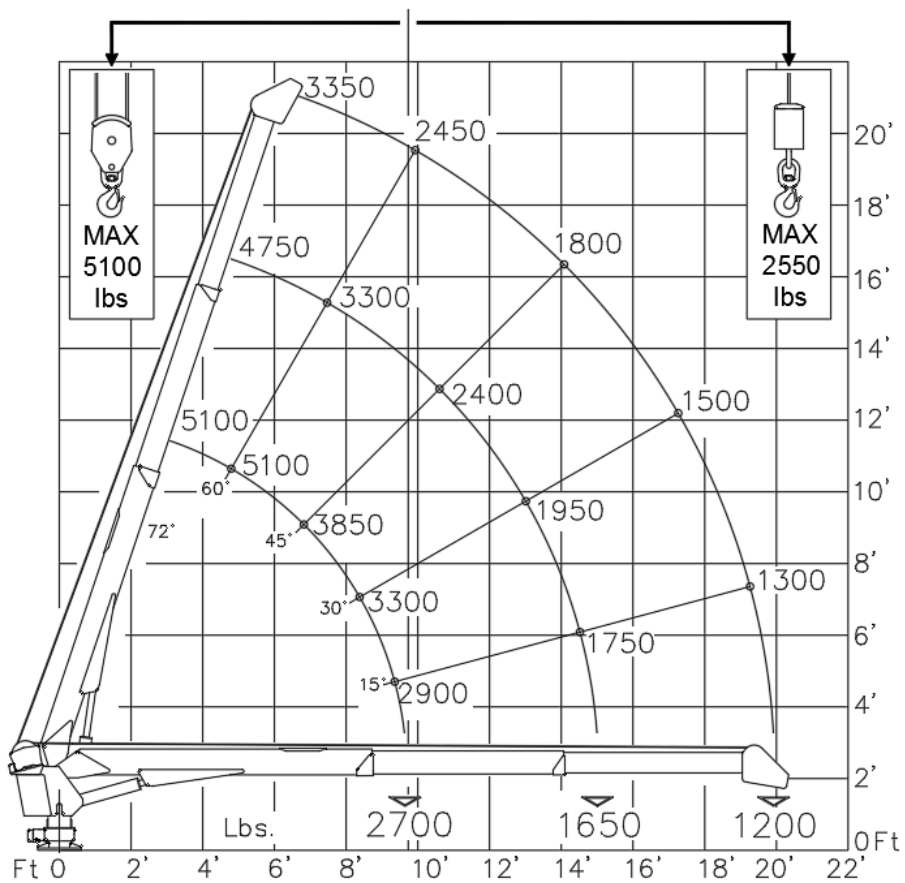
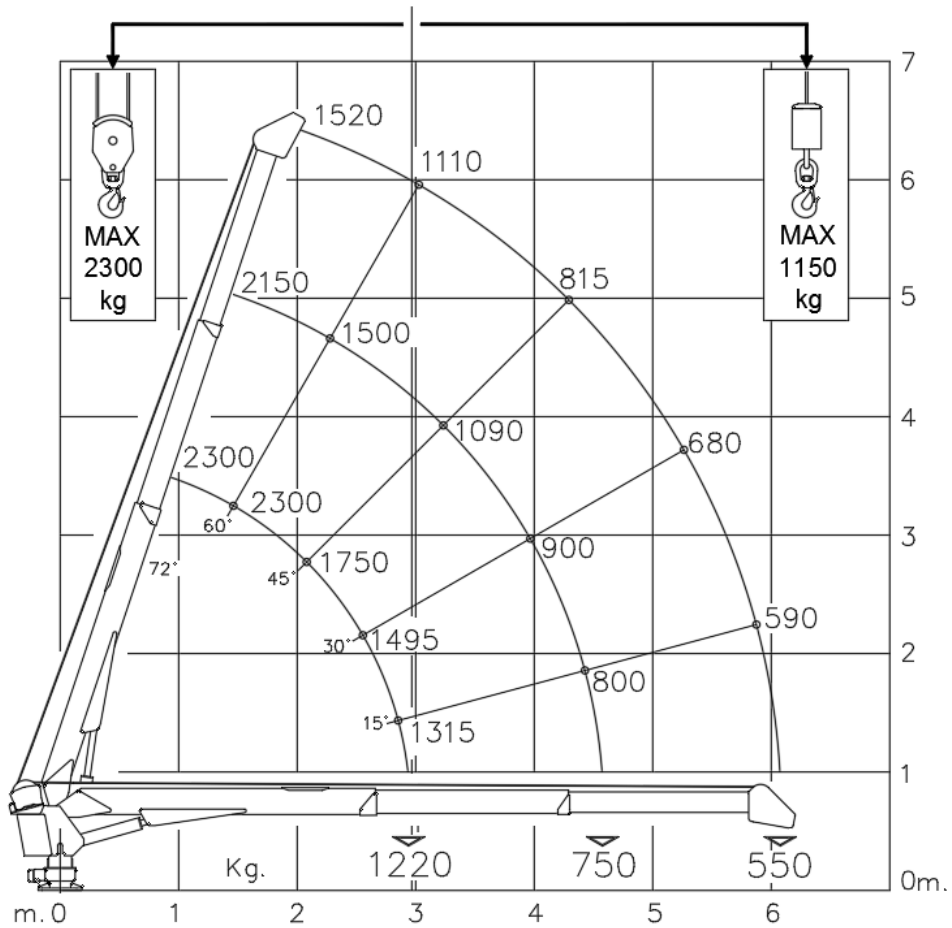

TECHNICAL DATA		Cobra 5500	
CRANE RATING	kNm ft.lbs	34 25000	
EXTENSIONS TYPE		2 HYDRAULIC	
HYDRAULIC EXTENSION	m ft	3 9' 10"	
HORIZONTAL REACH (from center line of rotation)	m ft	6.1 20'	
LIFTING HEIGHT FROM BASE OF CRANE	m ft	6 20'	
SLEWING ANGLE	°	CONTINUOUS	
SLEWING TORQUE	kNm ft.lbs	3.5 2500	
BOOM ELEVATION ANGLE	°	-5°/ +72°	
MAX. WORKING PRESSURE	bar psi	175 2540	
SUGGESTED OIL FLOW (H version)	l/min gpm	12 3.2	
OIL FLOW (E version)	l/min gpm	6 - 10 1.6 - 2.65	
CRANE WEIGHT (H version)	kg lbs	490 1080	
CRANE WEIGHT (E version)	kg lbs	520 1140	

WINCH SPECIFICATIONS		
WINCH SINGLE LINE CAPACITY (1 ST layer)	kg lbs	1420 3130
WINCH SINGLE LINE CAPACITY (3 RD layer)	kg lbs	1150 2550
WINCH PULL LINE SPEED (2 ND -3 RD layer – H version)	m/min ft/min	10 33
WINCH PULL LINE SPEED (2 ND -3 RD layer – E version)	m/min ft/min	5 – 9.5 16.4 – 31.2
WIRE ROPE DIAMETER	mm in	8 5/16"
WIRE ROPE LENGTH	m ft	30 98' 5"





