



HIGHLIGHTED FEATURES

- Unibody Longsills
- 1" Lower Center Of Gravity Compared To Crossmember Design
- Side & Tailgate: Double Wall For Heavy-Duty Application
- Tailgate: Upper & Lower Latches Provide Improved Safety To Operator
- Materials Chosen Strategically To Maximize Longevity Of Your Work Truck & Payload Capacity
- Easy To Mount And Install

Voth's Unibody design has been a trusted and proven dump body since 2003. Available in Aluminum, Steel or a Hybrid (Aluminum Sides & Tailgate on steel body). The Voth Unibody dump has a sleek understructure supported by longsills. Easy to install and features a low mounting height that provides a lower center of gravity and increased stability on the road or on the job site.

The overall design is robust, durable, and compact which pairs well with light and medium truck chassis. The original Steel Unibody provides a heavy-duty, hard-working truck design without sacrificing efficiency and functionality. Meanwhile the Aluminum Unibody optimizes your payload capacity with a lighter body and provides added corrosion resistance while maintaining the strength and integrity commonly associated with steel bodies.



STEEL



HYBRID

Steel Body with Aluminum Fold Down Sides & Tailgate



ALUMINUM

	STEEL				HYBRID				ALUMINUM			
UNIBODY SIZE	9'9"	11'9"	12'9"	13'9"	9'9"	11'9"	12'9"	13'9"	9'9"	11'9"	12'9"	13'9"
RECOMMENDED CA	60" CA	84" CA	108" CA	108" / 120" CA	60" CA	84" CA	108" CA	108" / 120" CA	60" CA	84" CA	108" CA	108" / 120" CA
HEADBOARD HEIGHT OPTIONS	53" / 60" / 66" / 72"				53" / 60" / 66" / 72"				53" / 60" / 66" / 72"			
FOLDING SIDE WALL HEIGHT OPTIONS	14" / 20"		14"	14"	14" / 20"				14" / 20"			
FOLDING SIDES	Single		Split		Single		Split	Single		Split		
TAILGATE HEIGHT OPTIONS	20" / 26"		20"	20"	20" / 26"				20" / 26"			
FOLDING SIDE MATERIAL	10 & 12 GA Steel				3/16" Aluminum 5052-H32				3/16" Aluminum 5052-H32			
TAILGATE MATERIAL	10 & 12 GA Steel				3/16" Aluminum 5052-H32				3/16" Aluminum 5052-H32			
HEADBOARD MATERIAL	10 GA Steel 44/50W				10 GA Steel 44/50W				3/16" Aluminum 5052-H32			
FLOOR MATERIAL	3/16" Steel 44/50W				3/16" Steel 44/50W				1/4" Aluminum 5083-H32			
REAR LIGHTING	LED 4 - STT, 2 Reverse, 5 Rear Markers, 2 Front Markers				LED 4 - STT, 2 Reverse, 5 Rear Markers, 2 Front Markers				LED 4 - STT, 2 Reverse, 5 Rear Markers, 2 Front Markers			
WEIGHT RANGE (LBS)	2411 - 2549	2670 - 2841	2904 - 2856	3282 - 3545	2193 - 2280	2423 - 2789	2642 - 2804	2693 - 3204	1509 - 1541	1601 - 1662	1706 - 1748	1733 - 1937

Specs subject to change without notice. Consult with factory for more information.

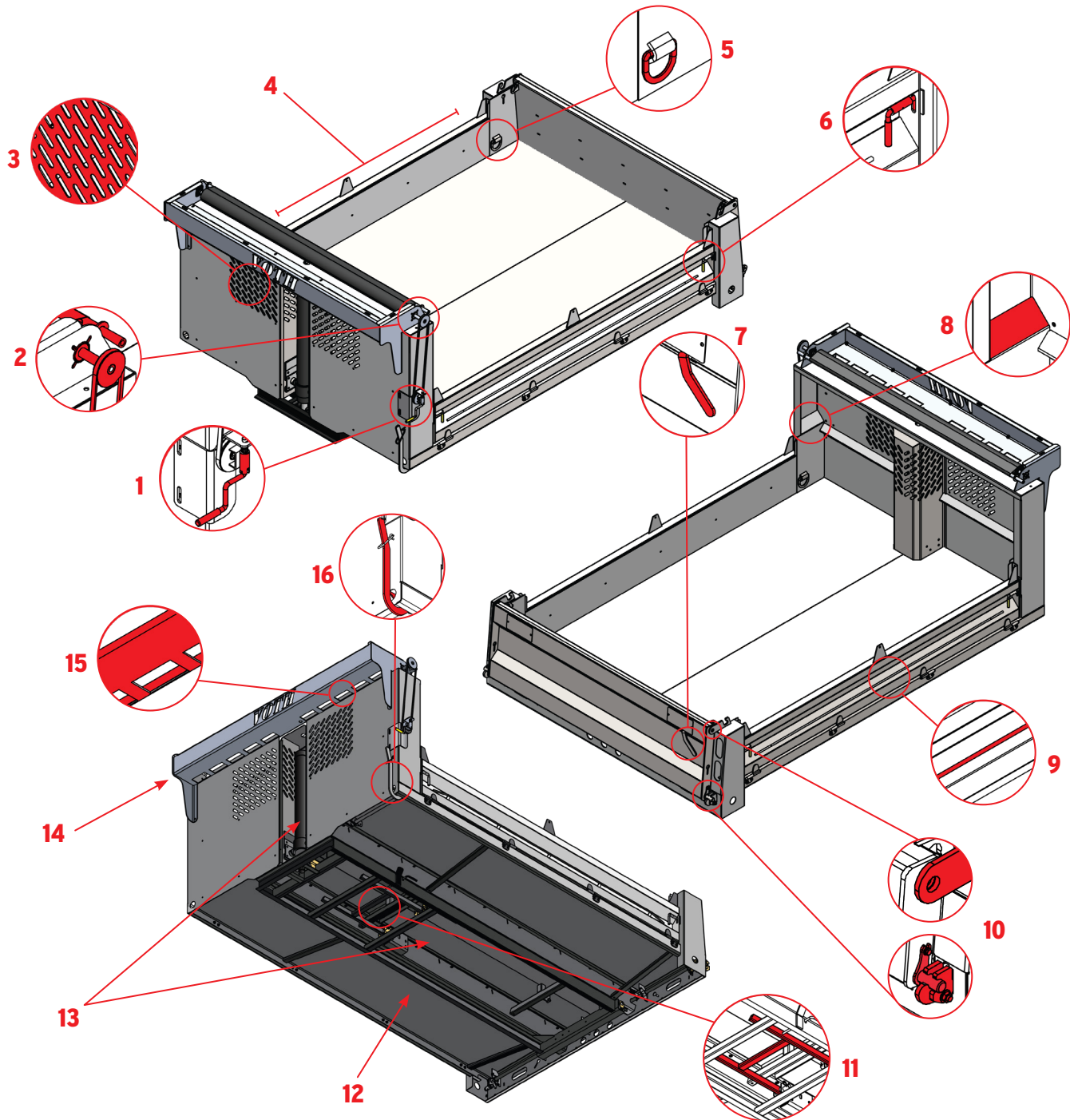

UNIBODY FEATURES

- 1. EASY ACCESS FOLD AWAY/LOCKABLE TARP CRANK
- 2. BLACK HEAVY DUTY MESH TARP WITH STEEL SEALED BEARINGS AND ALL STAINLESS STEEL HARDWARE
- 3. CNC CUT WINDOW
- 4. POCKETS FOR ALUMINUM OR WOOD SIDE EXTENSIONS
- 5. D-RINGS IN ALL 4 CORNERS
- 6. STAINLESS STEEL DOOR LATCHES
- 7. TAILGATE RELEASE LATCH (TO OPEN)
- 8. DEBRIS SHEDDING FRONT POSTS
- 9. TARP TIE-DOWN RODS ON SIDES
- 10. TAILGATE LATCHES FOR TWO-WAY ACTING TAILGATE
- 11. SAFETY STAND
- 12. UNIBODY DESIGN FLOOR
- 13. CHOICE OF EAGLE OR MAILHOT TELESCOPIC CYLINDER OR CHAMPION SCISSOR HOIST
- 14. 9" CABSHIELD

- 15. SHOVEL RACK CUT OUTS INTEGRATED INTO CABSHIELD
- 16. DUMP RELEASE LATCH (TO DUMP)

OPTIONS

- GRAVEL CHUTE
- REMOVABLE CHIPPER HOOD
- TOOL/SHOVEL RACK BASE