

VN-550/555-MHI

Powerful Non-Overcenter Material Handler

- **WORKING HEIGHT:** Up to 60 ft 6 in (18.4 m)
- **HORIZONTAL REACH:** Up to 42 ft 10 in (13.0 m)
- **PLATFORM CAPACITY:** Up to 700 lbs (318 kg)
- **JIB CAPACITY:** Up to 2000 lbs (905 kg)



VN-555-MHI model shown here.

TruGuard®
STANDARD

**SIMPLE
MECHANICAL
LINKAGE**
FOR BOOM
COMPENSATION

VERSALIFT®

**LOWER TRUE
COST OF
OWNERSHIP**

VN-550/555-MHI

Powerful Non-Overcenter Material Handler



VN-550-MHI

VN-555-MHI

GENERAL SPECIFICATIONS:

(Based on 40 in Frame)

Horizontal Reach	39.1' (11.9 m)	42.8' (13.0 m)
Platform Capacity Single 1-Man	400 lbs (180 kg)	400 lbs (180 kg)
Platform Capacity Single 2-Man	700 lbs (318 kg)	700 lbs (318 kg)
Rotation	360° Continuous	360° Continuous
Platform Rotation	90°	90°
Height to Bottom of Platform	50.6' (15.4 m)	55.5' (16.9 m)
Working Height	55.6' (16.9 m)	60.5' (18.4 m)

Stowed Travel Height	12.3' (3.74 m)
Maximum Jib Capacity	2000 lbs (900 kg)
Upper Boom Articulation	192° Relative to Lower Boom
Lower Boom Articulation	120°

INSULATION GAP:

Upper Boom	9.0' (2.7 m)
Lower Boom	18" (46 cm)

HYDRAULIC SYSTEM:

Operating Pressure	3000 psi (207 bar)
Flow Rate at Engine Idle	8 gpm (30 lpm)
Flow Rate with Auto Throttle Control Engaged	12 gpm (45 lpm)

Filtration	10 micron pressure 10 micron return 100 mesh suction
System Type	Open Center

OPTIONS:

- Automatic Boom Latch
- Various Auxiliary Outriggers
- Backup 12-Volt Pump
- Platform Tilt at Lower Controls
- Hydraulic Jib Pole Extension
- Lift Eye (2500 lb max)
- Platform Elevator
- Various Pedestal Heights
- Various Platforms, Covers and Liners

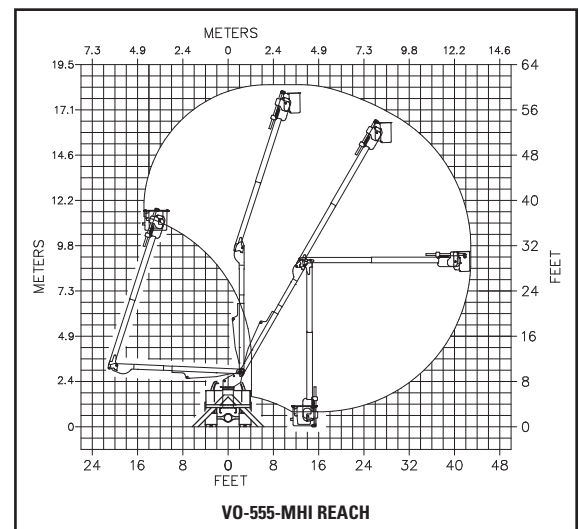
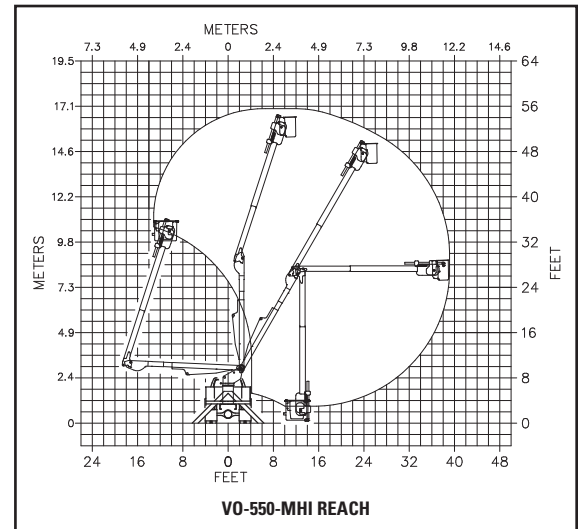

Note: Specifications on units may vary or change without prior notification due to option selections.

REV. 09/19

VERSALIFT is a leading manufacturer of bucket trucks, digger derricks and cable placers. Customers in the electric utility, telecommunications, forestry and sign, light & traffic industries experience a lower true cost of ownership by choosing Versalift. Our equipment is engineered to be lighter, while keeping the designs simple, which provides advantages like less unscheduled maintenance, greater payloads and ease of maintenance. Versalift has the lowest recall rate in the industry making it the smarter and most reliable choice. Versalift aerial lifts are the only units to feature the patented TruGuard® safety system, which provides additional protection to linemen in the bucket. Versalift is a Time Manufacturing Company, and together with Aspen Aerials has more than 1,000 employees worldwide.