

KARGO KING 2PL Roll off System

# cSixSeries

Model **TS-11-18-21**

TOW SYSTEM



TAKING SAFETY TO A NEW GROUND LEVEL FOR

# SPECIALTY AUTOMOBILES

**KARGO KING**  
ROLL-OFF SYSTEMS

- Designed for Class 6/7 Truck Applications
- Payload Capacity\* = 11,000lbs
- Sub-frame weight = 2,310 lbs
- Central Hydraulics = PTO & Pump Drive

## TAKING SAFETY TO A NEW GROUND LEVEL FOR... SPECIALTY AUTOMOBILES



### SUB-FRAME FEATURES:

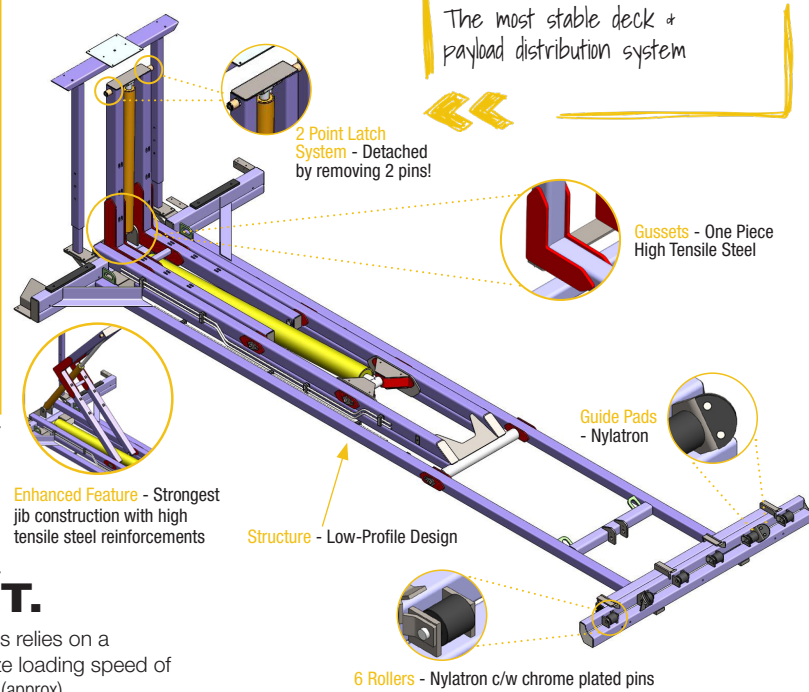

**SAFE.** Safe Ground Level Loading  
The shallow angle of the beavertail allows for easy loading by the operator in just about any weather condition.

**SIMPLE.**  
2PL = 2-Point Latch System  
Detach by removing two pins!

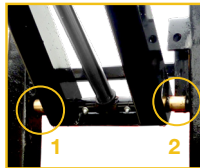

**EFFICIENT.**  
The Kargo King cSix series relies on a hydraulic circuit to optimize loading speed of **40 Seconds Cycle Time** (approx)

### KEY FEATURES

- Safe Ground Level Loading for Specialty Automobile
- Fast Cycle Time
- Low Center of Gravity
- 2 Point Latch System
- Easy to operate - 2 Control Levers Outside Controls (Driver's Side)
- Loading Angle = 25°
- Reliable & Low Maintenance
- Safe, Stable and Secure
- Deck is detachable
- Hard piped hydraulic plumbing

### STANDARD FEATURES

- Custom Aluminum Diamond Plate Bumper with Hitch, Lighting and 7-way Trailer Plug
- Aluminum Diamond Plate Fenders
- 16' LED Warning Light and Stand
- Easily Maintained with few Grease Points

### DECK FEATURES

- Deck Dimensions: 21' (L) x 102" (W)
- Ultrashallow Beavertail
  - 8° Low Approach for Equipment with Low Clearance
- Multiple Tie-Downs, Chain Tray
- Steel Checker Plate Floor
- Removable Winch Option

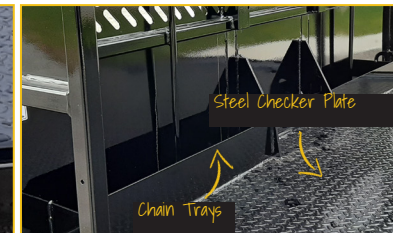

\*Dependant on truck configuration selected.